

PAPER • OPEN ACCESS

Analytical and experimental analysis of tube coil heat exchanger

To cite this article: R Smusz 2016 *J. Phys.: Conf. Ser.* **745** 032083

View the [article online](#) for updates and enhancements.

Related content

- [Experimental analysis of direct current corona discharge](#)
A Iagr, C M Dini and G N Popa
- [Testing of a 4 K to 2 K heat exchanger with an intermediate pressure drop](#)
P Knudsen and V Ganni
- [Reliability analysis on a shell and tube heat exchanger](#)
S Lingeswara, R Omar and T I Mohd Ghazi



IOP | ebooks™

Bringing you innovative digital publishing with leading voices to create your essential collection of books in STEM research.

Start exploring the collection - download the first chapter of every title for free.

Analytical and experimental analysis of tube coil heat exchanger

R Smusz¹

Department of Thermodynamics and Fluid Mechanics
Rzeszow University of Technology,
Al. Powstańców Warszawy 12, Rzeszów, 35-595, Poland
E-mail: robsmusz@prz.edu.pl

Abstract. The paper presents the analytical and experimental analysis of heat transfer for the finned tube coil heat exchanger immersed in thermal storage tank. The tank is equipped with three helical-shaped heating coils and cylindrical-shaped stratification device. Two coils, upper and lower, use the water as a heating medium. The third, double wall heat exchanger coil, located at the bottom head on the tank is filled by the refrigerant (freon). Calculations of thermal power of water coil were made. Correlations of heat transfer coefficients in curved tubes were applied. In order to verify the analytical calculations the experimental studies of heat transfer characteristic for coil heat exchanger were performed.

1. Introduction

Heat exchangers have widespread industrial and domestic applications. They are used in power plants, nuclear reactors, refrigerators, air conditioning systems, automotive industries, chemical processing reactors, food industries, and hot domestic water systems. The coiled tube heat exchangers offers an unique advantages: simultaneous heat transfer between more than two streams, a large number of heat transfer unit and high operating pressure. Therefore coiled tube heat exchangers are one of the three classical heat exchangers, i.e. shell and tube, double pipe and coiled tube used for large scale liquefaction systems. Helical coils are used for various processes because they can accommodate a large heat transfer area in compact space, with high heat transfer coefficient.

In general they can be used as coolers, heaters, condensers or evaporators. Helical coil heat exchangers are widely used because of their compact structure, ease of production, and mainly due to the increase of heat transfer rate in comparison with straight pipe heat exchangers. The centrifugal force induced due to the curvature of the tube results in the secondary flow known as Dean Vortex [1] superimposed on the primary flow which enhances the heat transfer [2], [3]. Many studies have been carried out to investigate the heat transfer characteristics in the coiled tubes.

The authors in [2] describe the increase of heat transfer in helical coil heat exchanger compared to straight pipe exchanger. In turn the study [3] presents the results of the investigation of heat transfer enhancement in coil heat exchangers with helical corrugation of the coil. Helical coil exchangers were also the subject of many other investigators. As examples, one could mention the works: [4], [5], [6], [7], [8], [9] and [10]. The paper [4] gives the results of thermal performance investigations on heat exchangers with concentric helical coils. The authors pay attention to the strong influence of geometric parameters on heat transfer coefficients. The work [5] focused on the

¹ robsmusz@prz.edu.pl



coil heat exchangers immersed in solar thermal storage. The authors present some factors influencing on improvement the knowledge of immersed coil heat exchangers, these include heat exchangers capacity rates for tall coils, natural convection caused by heat loss of tanks with low values of height to diameter ratios, and the topic of heat exchangers of varying ratios of coil pitch to its diameter. In [6], [7], [8] and [9] the authors present the results of experimental study on natural convective heat transfer from helical coil pipes in different fluids: in air, water, glycerol-water solution and in oil respectively. Some new empirical correlations have been proposed. In turn the paper [10] described the experimental investigation on pressure drop for helical coils. The author developed the generalized pressure drop correlations in geometrical terms characteristic for helical coil.

The aim of this work was to describe the thermal performance of a vertical hot water storage tank during the dynamic mode of operation. The considered storage tank consists of three vertical coils which are designed to warm up the hot domestic water in the storage tank. Two coils, upper and lower, use the water as a heating medium. The third, double wall heat exchanger coil, located at the bottom head on the tank is filled by the refrigerant (freon) that transfers the waste heat from refrigeration or air conditioning system during the processes of condensation of the refrigerant [11]. Pipes of all coils are finned. Additionally the tank is equipped with stratification device designed for improving of water stratification level. In order to prevent possible refrigerant leakage, the special buffer layer filled with the nanofluid is mounted in the freon coil. The gap is filled by the nanofluid consisting of distilled water and copper nanoparticles. Nanofluid was used for reduce a thermal resistance of the buffer layer.

Analytical calculations of thermal power for lower water coil were made. Correlations of heat transfer coefficients in curved tubes were applied. In order to verify the analytical calculations the experimental studies of heat transfer for coil heat exchanger were performed.

2. Experimental setup and procedure

The simplified scheme of the test rig is shown in Fig. 1. The test stand consisted of the storage tank equipped with three finned tubular coiled heat exchangers: water coils and freon coil; thermostat and additional buffer tank.

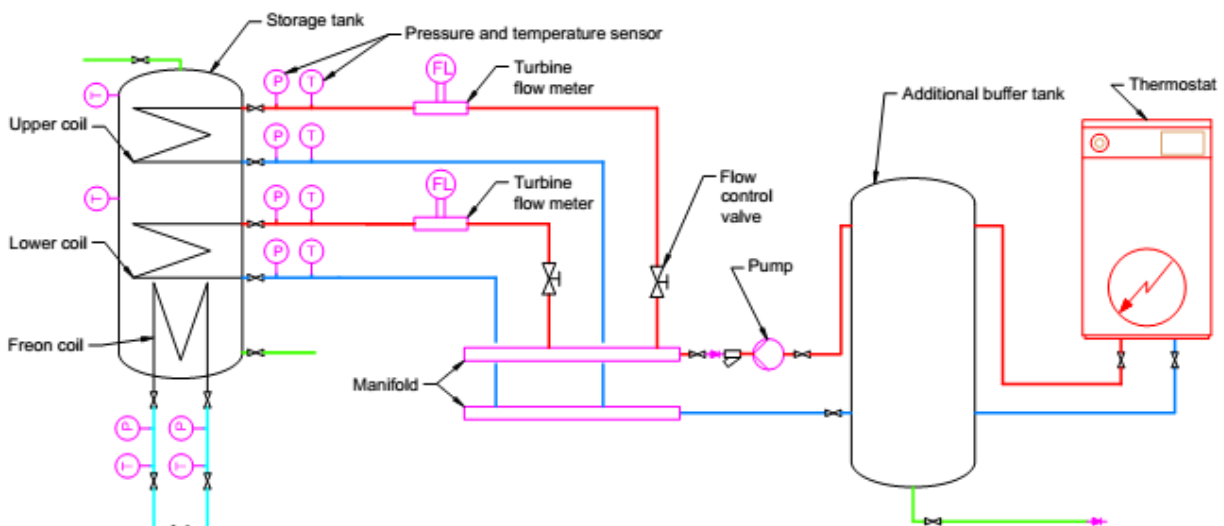

Figure 1. Scheme of the experimental rig

Upper and lower coils were supplied with water heated in the thermostat. For the stabilization of heating water temperature the buffer tank was applied. The freon coil was connected with the air-conditioning system. For determining the mean temperature of domestic hot water in the storage tank

\bar{T} , the eight resistive temperature sensors M-FK 1020 (Heraeus Sensor – Nite GmbH) were mounted on the outer surface of the tank as is shown in Fig.2.

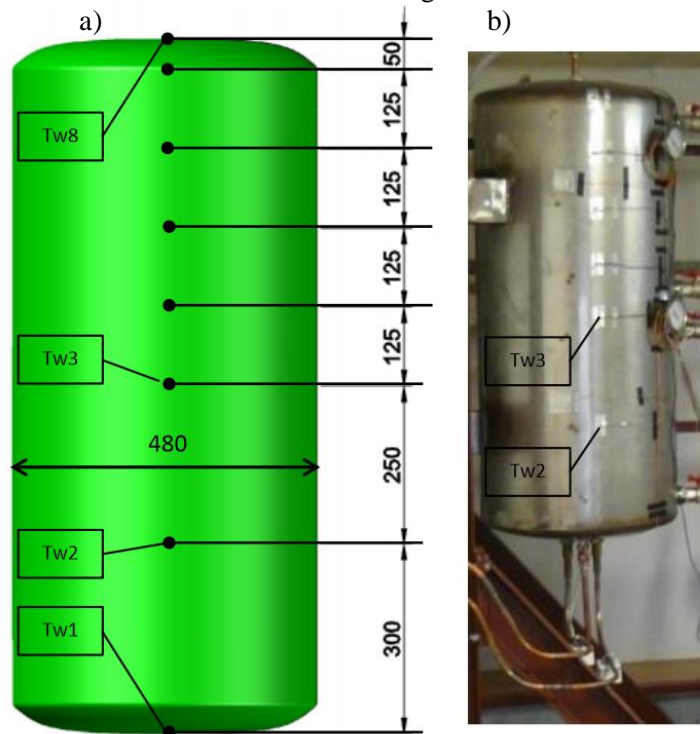

Figure 2. Location of temperature sensors Tw1÷Tw8 on the outer surface of the storage tank
 a) dimensions of the tank
 b) photograph of the real storage tank

Because of tank walls were made of stainless steel with a thickness of 2 mm, the mean water temperature in the storage tank was taken as the average value of the temperature measured on the outer tank surface. Geometrical characteristics of the finned pipe of the applied lower water coil are summarized in Table 1. In order to obtaining of the thermal power of the lower water coil exchanger, measurements of temperatures of heating medium (water) at the inlet and at the outlet of the coil, and volume flow rate of heating water were performed. Six resistive temperature sensors AP-TOP-VFGPt100 (Kompart Pomiar) and two turbine flow meters TM44 (Tecfluid) were used. Thermal power of water coil was calculated according to the formula

$$\dot{Q} = \dot{V} \cdot \rho \cdot c_w (T_1 - T_2), \quad (1)$$

where: T_1, T_2 – temperatures of heating water at the inlet and at the outlet of the coil, respectively, \dot{V} – volume flow rate of heating water, c_w, ρ – temperature dependent water heat capacity and density, respectively.

The product $\rho \cdot c_w$ from eq.(1) was calculated according to the formula

$$\rho \cdot c_w = 4211.7 - 1.6796 \frac{T_1 + T_2}{2}. \quad (2)$$

The eq.(2) is an approximation of literature data [12].

The results of temperature measurements and thermal power calculations are showed in Fig.3.

Figure 3 presents the thermal charging process of the tank by the lower water coil with fixed volume flow rate of heating water $\dot{V} = 0.584 \text{ m}^3/\text{h}$. As can be seen the temperature of heating water at the inlet of the coil remains almost constant after short thermal start-up. Its mean value is 40.45°C . The decrease of thermal power of the coil pipe during the exchanger operation time is observed. It results

from the increasing of the temperature of heated water and the same from the reduction of thermal forces for heat transfer processes.

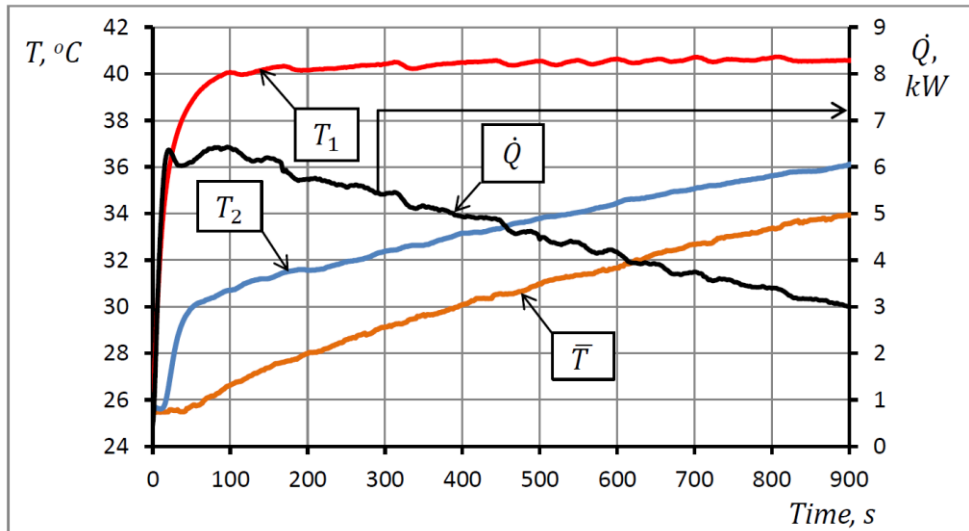

Figure 3. Changes of temperature of heating water at the inlet and outlet of the coil exchanger T_1, T_2 ; mean temperature of heated water \bar{T} , measured thermal power of the coil exchanger \dot{Q} vs. time

3. Analytical calculations

Heat transfer processes in considered heat exchanger with vertical coil include convective turbulent flow inside the coil pipe, heat conduction through coil pipe wall and natural convection outside the coil. Convective heat transfer inside the coil occurs with the pressure drop on the coil pipe sections. In order to obtain thermal characteristics of the exchanger the calculations of thermal power were made. Convective heat power from water coil \dot{Q}_w is given by general form

$$\dot{Q} = \Delta T_{\log} \cdot A \cdot U = \dot{V} \cdot \rho \cdot c_w (T_1 - T_2) \quad (3)$$

where ΔT_{\log} – logarithmic mean temperature difference from eq.(2):

$$\Delta T_{\log} = \frac{(T_1 - \bar{T}) - (T_2 - \bar{T})}{\ln\left(\frac{T_1 - \bar{T}}{T_2 - \bar{T}}\right)}, \quad (4)$$

where: T_1, T_2 – temperatures of heating medium (water) at the inlet and at the outlet of the coil, respectively, \bar{T} – mean temperature of domestic hot water in storage tank, \dot{V} – volume flow rate of heating water, c_w, ρ – temperature dependent water heat capacity and density, respectively.

The overall heat transfer coefficient U in eq. (3) is given by

$$U \cdot A = \frac{1}{\frac{1}{h_i \cdot A_{ip}} + R_k + \frac{1}{h_{eq} \cdot A_{in_f} + h_{eq} \eta_f N_f A_f}}, \quad (5)$$

where: A – overall coil pipe surface, h_i – heat transfer coefficient at the inner surface of the coil pipe A_{ip} , R_k – conduction thermal resistance of the coil pipe dependent on the material and the thickness of the pipe wall, h_{eq} – equivalent heat transfer coefficient of the finned surface, A_{in_f} and A_f – tube area between fins and the fin surface, respectively, η_f – fin efficiency, N_f – the number of fins. Necessary to calculations the coefficients h_i and h_{eq} were determined from the equations (6) and (7). Nusselt number for heat transfer during the turbulent flow through the water coil is given by [13]:

$$Nu = \frac{Re Pr f / 8}{1 + 12.7 \sqrt{\frac{f}{8}} (Pr^{2/3} - 1)}, \quad f = \frac{0.3164}{Re^{0.25}} + 0.03 \left(\frac{d_i}{D} \right)^{0.5}, \quad (6)$$

where: d_i – inner coil pipe diameter, D – characteristic diameter of the coil [11].

In turn, Nusselt number in the case of free convection from the surface of the finned pipe is in the form [14]:

$$Nu = 0.028(Gr \cdot Pr)^{0.4}, \quad (7)$$

where the characteristic dimension in Nusselt and Grashof numbers is the equivalent diameter for the finned pipe. The solution of equation (3), taking into account eq. (4-7), enables determination of thermal power of heat exchanger – lower water coil of the considered exchanger. Calculations were performed under assumption of temperatures T_l , \bar{T} and volume flow rate \dot{V} as in experimental research: $T_l = 40.45^\circ\text{C}$, \bar{T} is in the range $26.5 \div 34^\circ\text{C}$, $\dot{V} = 0.584 \text{ m}^3/\text{h}$. The dependence on temperature of thermophysical properties of water was taken into account in the calculations. Because of heat transfer coefficients are implicit temperature functions, the system of nonlinear equations was created. It was solved using the secant method. Table 1 presents dimensions of applied coil pipe with finned outer surface and the results of calculations and experimental measurements of thermal power of lower water coil of considered exchanger.

Table 1. Geometrical and thermal characteristics of lower water coil of considered exchanger

Outer diameter of finned coil pipe	18.5 mm	Mean coil diameter	385 mm
Inner diameter of coil pipe	16.5 mm	Coil pitch	41 mm
Fin height	3.5mm	Number of coils	10
Fin width	0.5 mm	Pipe material	copper
Number of fins per inch of coil pipe length	11	Coil pipe length	12.1 m
$T_l = 45.45^\circ\text{C}$		$\dot{V} = 0.584 \text{ m}^3/\text{h}$	
\bar{T} , °C	\dot{Q} from calculations, kW	\dot{Q} from experiment, kW	
26.5	6.51	6.53	
27	6.26	6.30	
28	5.77	5.84	
29	5.28	5.38	
30	4.79	4.92	
31	4.29	4.45	
32	3.80	3.99	
33	3.31	3.53	
34	2.82	3.06	

4. Final remarks

As the final result of theoretical and experimental investigations of considered heat exchanger the graph of the exchanger thermal power dependence on mean heated water temperature in the storage tank was built. It is presented in Fig.4. Thermal power from the experiment and from theoretical calculations are compared. The relationship between measured results of the power of coil and average temperature of the water in the tank is nearly linear. Therefore the results of the experiments were approximated by linear function. As can be seen differences between approximation of calculated and measured results are quite small. Maximum and minimum error is 8% and 0.4% respectively. For the analyzed range of water temperature in the tank the average error of calculated power of the exchanger is 3.3%. Hence, the conclusion that the applied calculation procedures can be used for the thermal analysis of finned tube coil heat exchangers immersed in thermal storage tank.

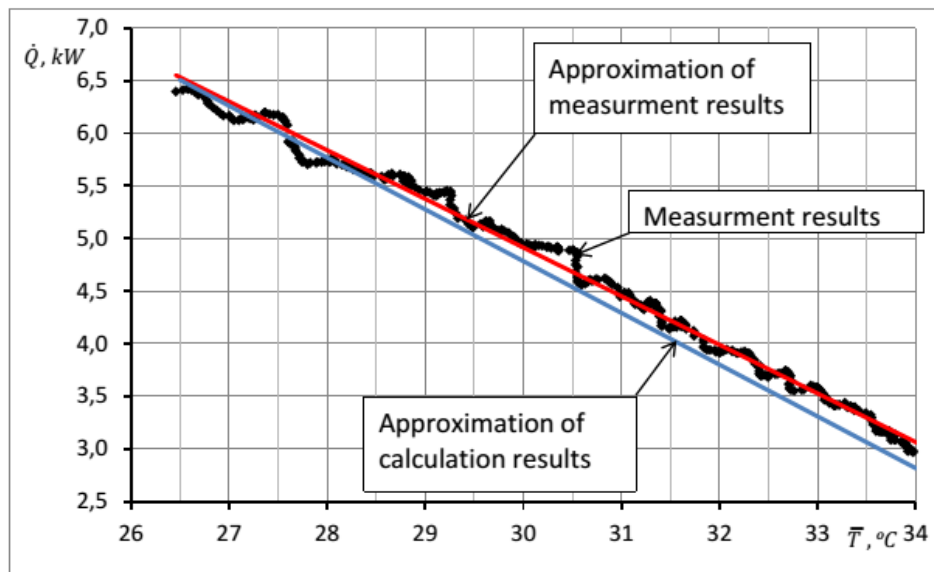

Figure 4. Thermal power of lower water coil exchanger vs. mean temperature of heated water

5. References

- [1] Dean W R 1927 Note on the motion of fluid in a curved pipe. *Philosophical Magazine, Series 7*, **4(20)** 208-233
- [2] Prabhanjan D G, Raghavan G S V and Rennie T. J 2002 Comparison of heat transfer rates between a straight tube heat exchanger and a helically coiled heat exchanger. *Int. Comm. Heat Mass Transfer* **29** 185-191
- [3] Zachár A 2010 Analysis of coiled-tube heat exchangers to improve heat transfer rate with spirally corrugated wall *International Journal of Heat and Mass Transfer* **53** 3928-3939
- [4] Genić S B, Jaćimović B M, Jarić M S, Budimir N J and Dobrnjac M M 2012 Research on the shell-side thermal performances of heat exchangers with helical tube coils *International Journal of Heat and Mass Transfer* **55** 4295-4300
- [5] Logie W 2007 Immersed Coil Heat Exchangers *Solartechnik Prüfung Forschung* **22** 1-11
- [6] Ali M E 1998 Laminar natural convection from constant heat flux helical coiled tubes. *International Journal of Heat and Mass Transfer* **41** 2175-2182
- [7] Prabhanjan D G and Rennie T J G and Raghavan G S V 2004 Natural convection heat transfer from helical coiled tubes *International Journal of Thermal Sciences* **43** 359-365
- [8] Ali M E 2004 Free convection heat transfer from the outer surface of vertically oriented helical coils in glycerol-water solution *Heat and Mass Transfer* **40** 615-620
- [9] Ali M E 2006 Natural convection heat transfer from vertical helical coils in oil *Heat Transfer Engineering* **27** 79-85
- [10] Ali S 2001 Pressure drop correlations for flow through regular helical coil tubes *Fluid Dynamics Research* **28** 295-310
- [11] Smusz R and Wilk J 2016 Coiled heat exchanger with the nanofluid filled buffer layer *Applied Mechanics and Materials* **831** 223-231
- [12] Main IAPWS Thermodynamics Property Formulations, Updated July 6, 2015, <http://www.iapws.org/newform.html>
- [13] Niezgoda-Żelasko B and Zalewski W 2013 *Chłodnicze i klimatyzacyjne wymienniki ciepła* Wydawnictwo Politechniki Krakowskiej, Kraków
- [14] Berkel H, Mitra N K and Fiebig M 1984 Experimentelle Untersuchung des Wärmeüberganges durch freie Konvektion an waagerechten Rippenrohren in einem zylindrischen Behälter. *Wärme und Stoffübertragung* **18** 167-173